

H10 Frontmaße (ohne/ mit Anbauleisten/ Röhrtür)

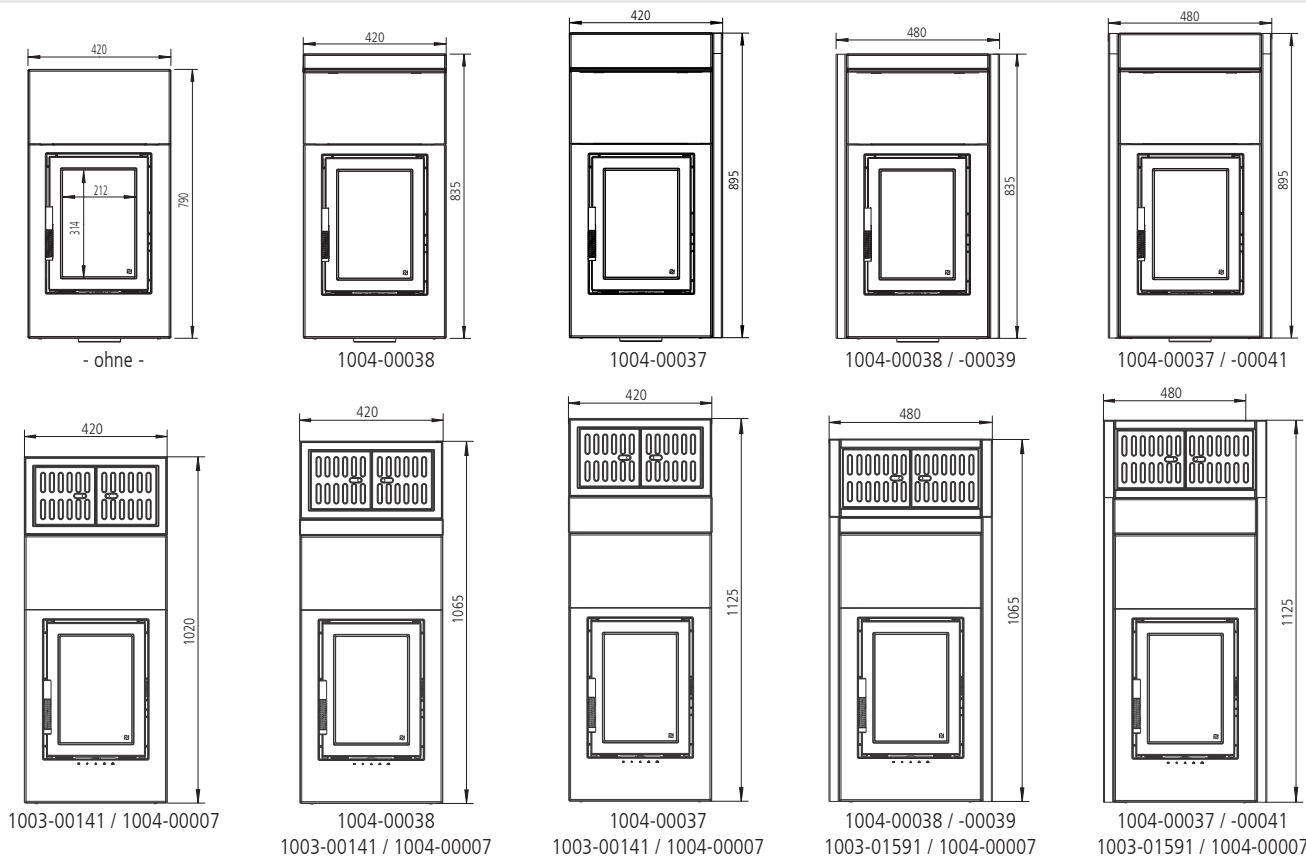

H20/ H13 Frontmaße (ohne/ mit Anbauleisten/ Röhrtür)

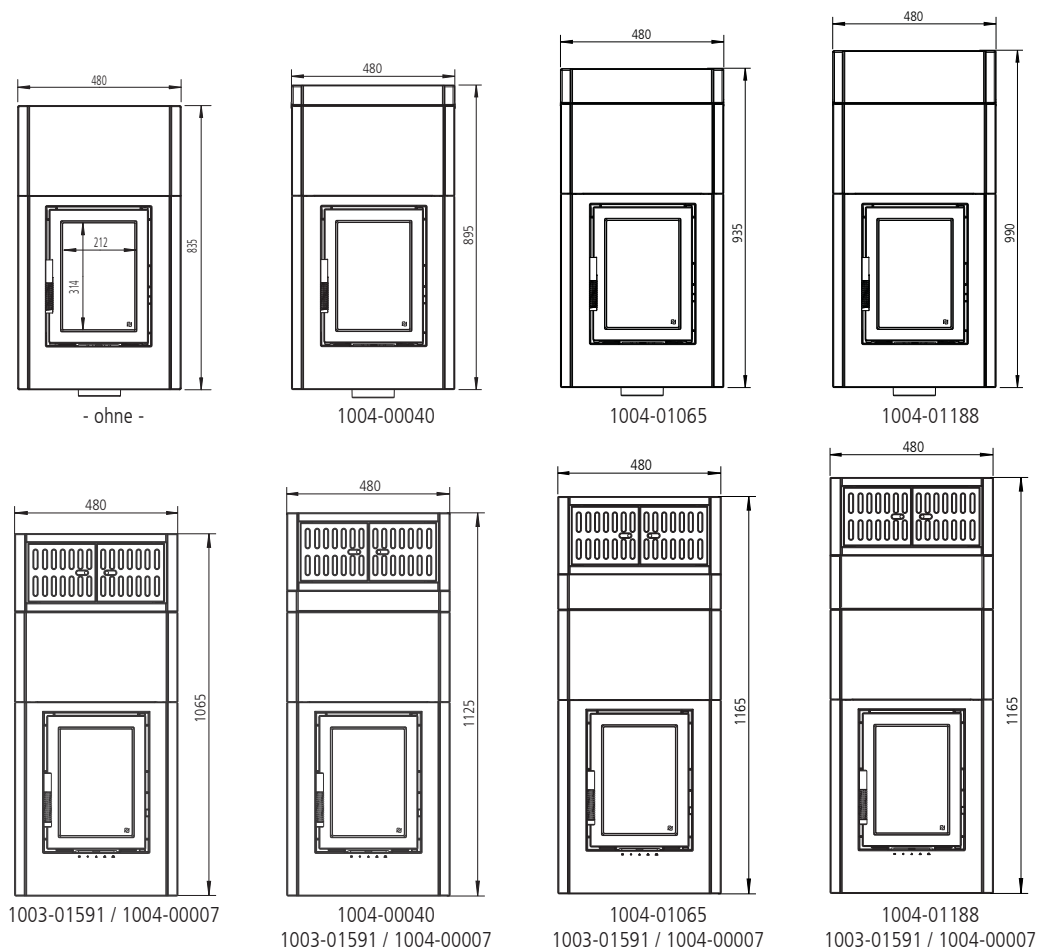

Heizeinbauten
DIAMANT

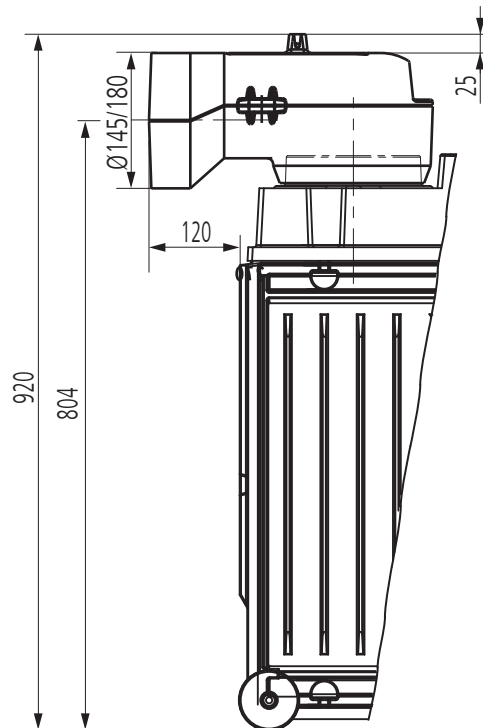
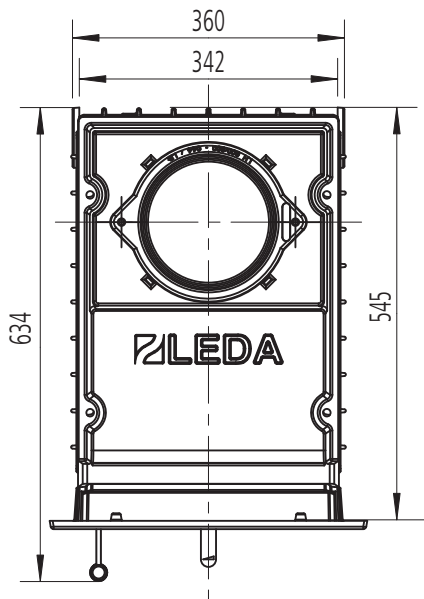
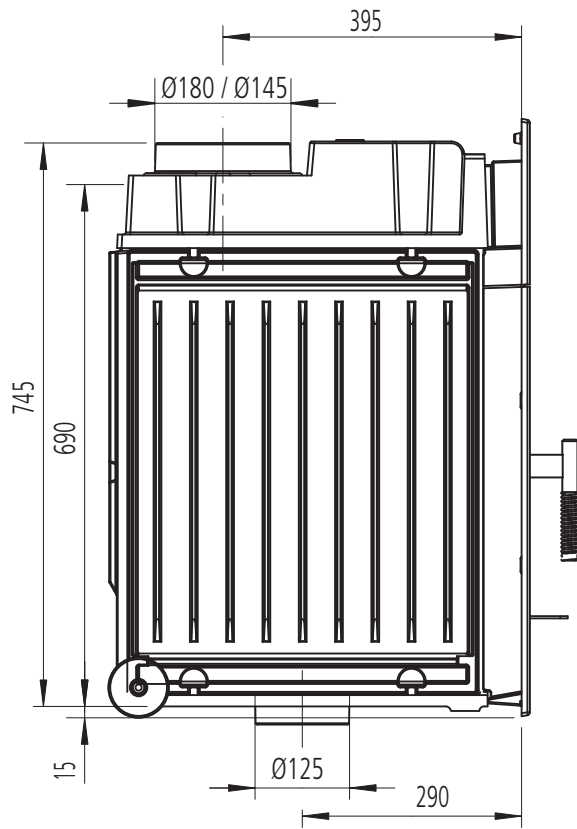
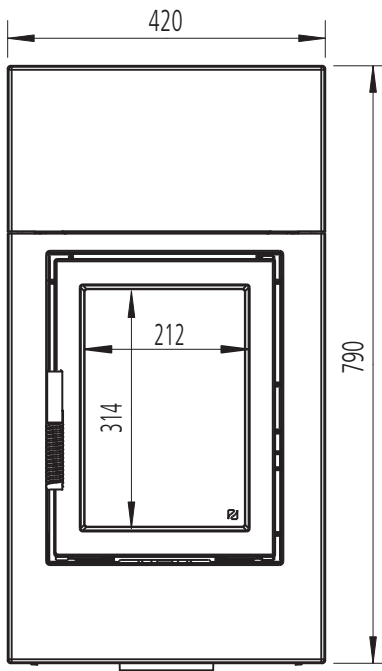

DIAMANT H10 mit waagrecht
Heizgasstutzen Ø 180mm (Zubehör)

DIAMANT H20 / M1:10

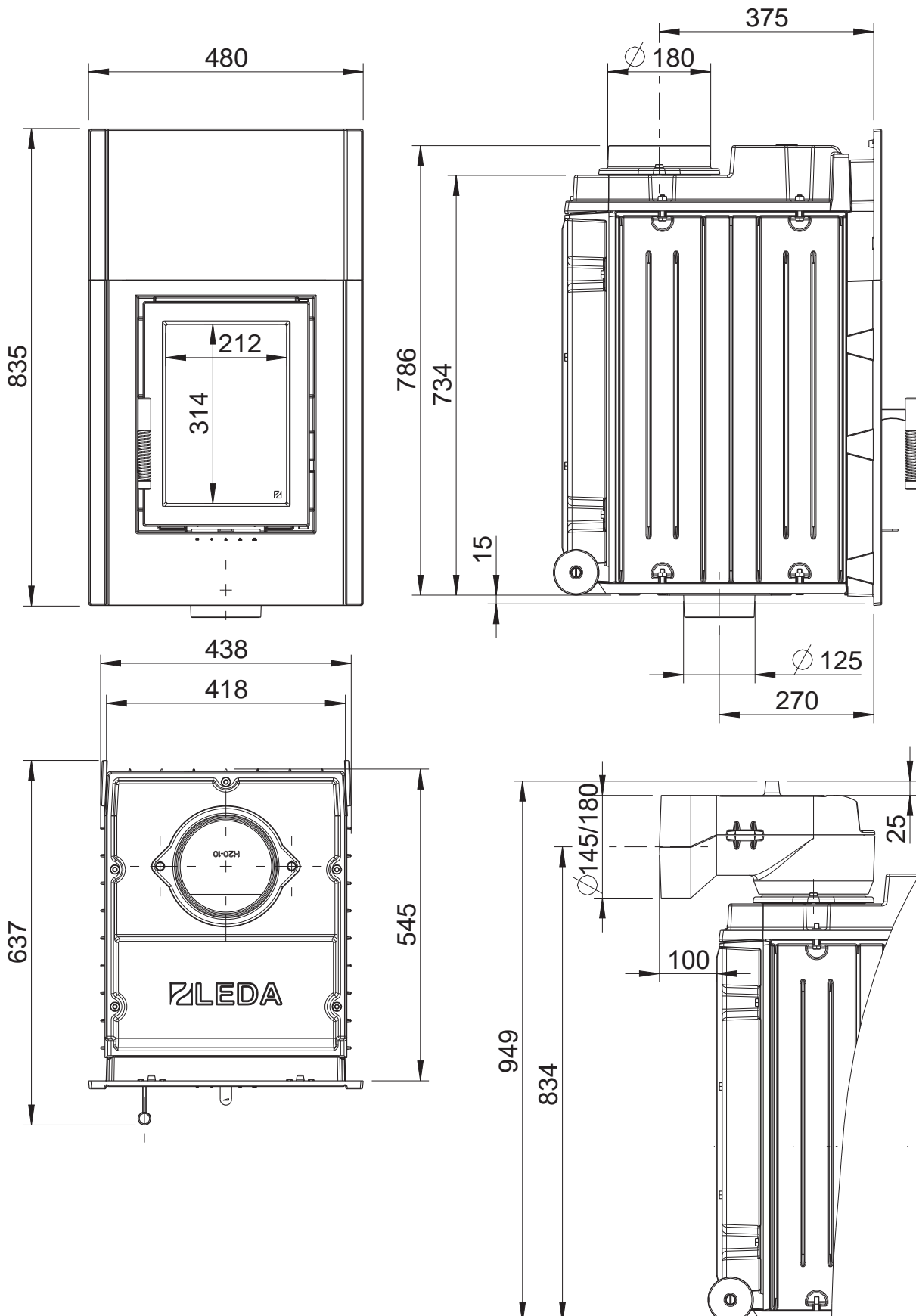

DIAMANT H20 mit waagrecht
Heizgasstutzen $\varnothing 180$ mm (Zubehör)

Heizeinbaut
DIAMANT

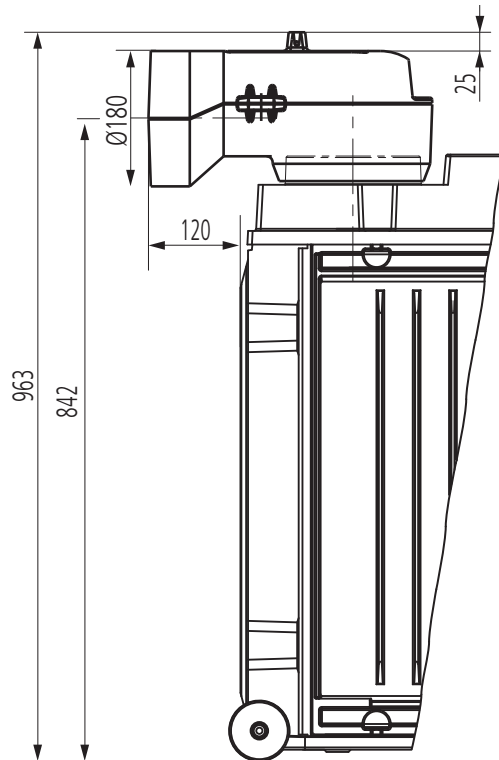
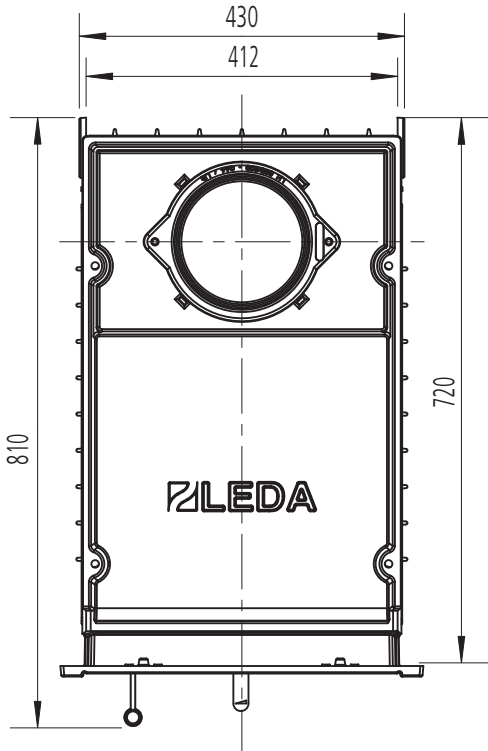
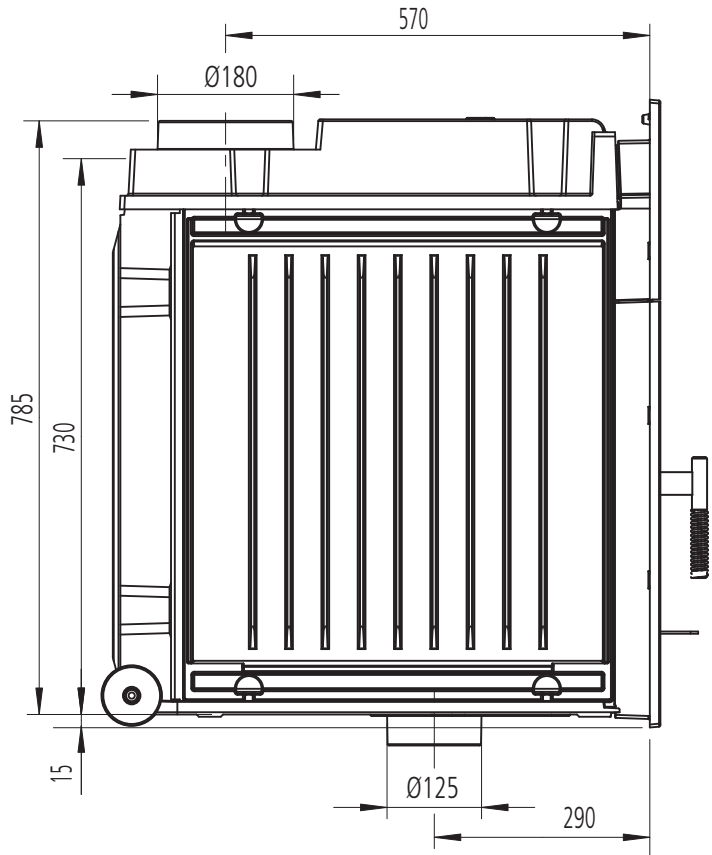
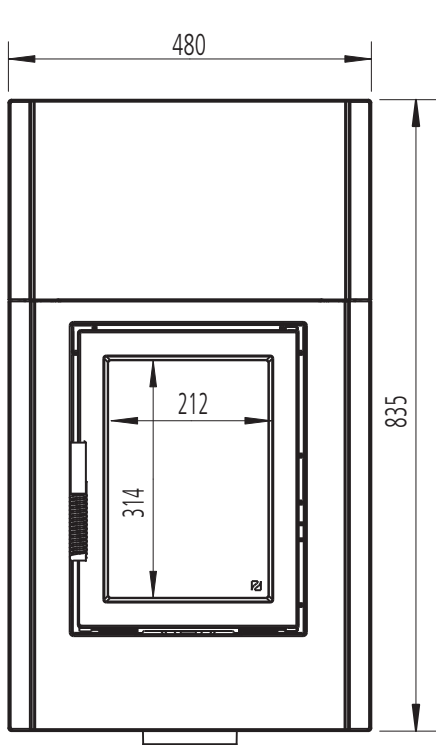

DIAMANT H13 mit waagrecht
Heizgasstutzen Ø 180mm (Zubehör)